

PERFORMANCE SPECIFICATION SHEET

FUSEHOLDERS, EXTRACTOR POST TYPE,
 BLOWN FUSE INDICATING, TYPE FHL13G

This specification is approved for use by all Departments and Agencies of the Department of Defense

The requirements for acquiring the product described herein shall consist of this specification and [MIL-PRF-19207](#).

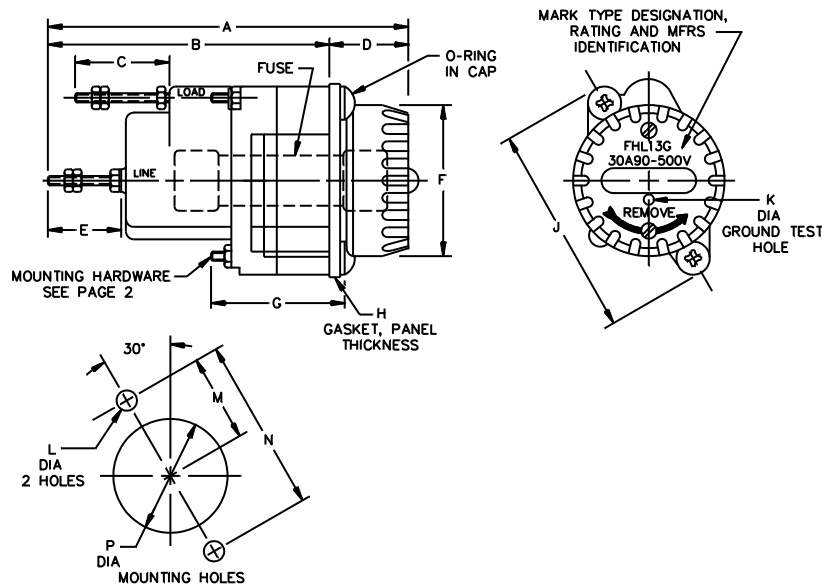

Ltr	Inches		mm		Ltr	Inches		mm	
	Min	Max	Min	Max		Min	Max	Min	Max
A	3.650 (REF)		92.71 (REF)		H	.055	.065	1.40	1.65
B	2.655 (REF)		67.44 (REF)		J	2.380 (REF)		60.45 (REF)	
C	.650 (REF)		16.51 (REF)		K	.091	.101	2.31	2.57
D	1.000 (REF)		25.40 (REF)		L	.205	.210	5.21	5.33
E	.5000 (REF)		12.70 (REF)		M	.935	.945	23.75	24.00
F	1.625	1.635	41.28	41.53	N	1.880	1.890	47.75	48.01
G	1.495	1.505	37.97	38.23	P	1.370	1.380	34.80	35.05

NOTES:

1. Dimensions are in inches.
2. Metric equivalents are given for general information only.
3. Unless otherwise specified, tolerance is .XXX ± .005 (.13 mm).

FIGURE 1. Type FHL13G fuseholders.

MIL-PRF-19207/4L

REQUIREMENTS:

Interface and physical dimensions: See [figure 1](#).

Cap and body molding material: It is recommended that types MAI-60, GDI-30F or SDG-F of American Society for Testing and Materials [ASTM-D5948](#) be considered for meeting the body molding material requirements of this specification. [ASTM-D3935](#) is also suggested as guidance for cap material.

The military part number is not required on the fuseholder.

Fuse accommodation:

Ferrule type:

Size: 0.563 inch (14.30 mm) diameter, 2 inches (50.8 mm) length.

Style: [MIL-PRF-15160](#), F15 and F61.

(or equivalent size and style).

Poles: One.

Rating: 30 amperes, 90 volts to 500 volts.

Panel thickness: 0.187 inch (4.75 mm) maximum.

Indicating: Neon lamp with clear cap.

Lamp series resistors: [MIL-PRF-39017/2](#) two resistors, 160,000 ohms, 0.5 watt, one each lamp lead.

Terminals: Stud type, No. 190-24 UNC-2A thread.

Enclosure: Dripproof.

Test fuses:

Temperature rise: F61C500V30A of [MIL-PRF-15160/61](#).

Short circuit: F61C500V30A of [MIL-PRF-15160/61](#).

Mechanical shock: Method I of [MIL-PRF-19207](#).

Terminal strength: 20 pounds.

Torque: Terminals and cap insert - 15 inch-pounds.

Salt atmosphere (corrosion): Test condition B.

Mounting hardware:

Screw: .190-24UNC-2A, truss head, 1.5 inches long (38.1 mm) (min) with sealing washer.

Nut: .190-24UNC-2B Hex. A threaded metal insert may be used in lieu of nut.

MIL-PRF-19207/4L

Part or Identifying Number (PIN): FHL13G-001 shall be for the body and supersedes the military part number: M19207/4-001 and FHL13G-002 shall be for the cap and supersedes the military part number M19207/4-002.

Referenced documents. In addition to [MIL-PRF-19207](#), this document references the following:

[MIL-PRF-15160](#) [MIL-PRF-15160/61](#) [MIL-PRF-39017/2](#) [ASTM-D3935](#) [ASTM-D5948](#)

The margins of this specification are marked with vertical lines to indicate where changes from the previous issue were made. This was done as a convenience only and the Government assumes no liability whatsoever for any inaccuracies in these notations. Bidders and contractors are cautioned to evaluate the requirements of this document based on the entire content irrespective of the marginal notations and relationship to the last previous issue.

Custodians:

Army - CR
Navy - SH
Air force - 85
DLA - CC

Preparing Activity:

DLA - CC

(Project 5920-2012-057)

Review Activities:

Army - AR, AT, CR4, MI
Navy - AS, EC, OS
Air Force - 70, 71

NOTE: The activities listed above were interested in this document as of the date of this document. Since organizations and responsibilities can change, you should verify the currency of the information above using the ASSIST Online database at <https://assist.dla.mil>.