

INCH-POUND

MIL-PRF-19207/17G

26 April 2005

SUPERSEDING

MIL-PRF-19207/17F

22 June 1999

PERFORMANCE SPECIFICATION SHEET

FUSEHOLDERS, EXTRACTOR POST TYPE,
NONINDICATING, NON-EMI/RFI SHIELDED AND EMI/RFI SHIELDED
TYPES FHN28W, FHN28WS, FHN28WB, AND FHN28WBS

This specification is approved for use by all Departments
and Agencies of the Department of Defense.

The requirements for acquiring the product described herein
shall consist of this specification and MIL-PRF-19207.

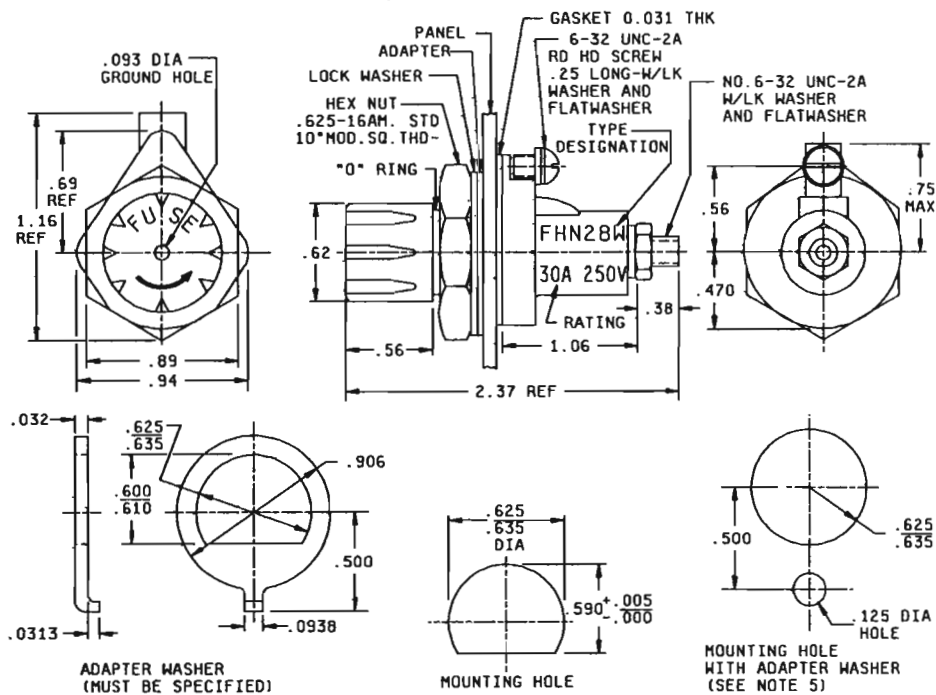

Inches	mm	Inches	mm	Inches	mm	Inches	mm	Inches	mm
.005	0.13	.25	6.35	.56	14.22	.625	19.05	.906	23.01
.031	0.79	.290	7.37	.590	14.99	.635	22.35	.94	23.88
.032	0.81	.38	9.65	.600	15.24	.69	23.88	1.06	26.92
.093	2.36	.47	11.94	.610	15.49	.75	60.20	1.16	29.46
.125	3.18	.500	12.70	.62	15.75	.88	15.88	2.37	60.20

FIGURE 1. Type FHN28W and type FHN28WB fuseholder.

NOTES:

1. Dimensions are in inches.
2. Metric equivalents are given for general information only.
3. Unless otherwise specified, tolerances are ± 0.02 (0.51 mm) for two-place decimals and ± 0.005 (0.13 mm) for three-place decimals.
4. Cap thread shall be 3/8-32NEF2 and provide for cap interchangeability.
5. Round hole mounting for replacement only. Use adapter washer for nonwatertight and non EMI/RFI applications only.
6. Marking: In addition to other required marking, the manufacturer's identification, the type designation, and the current and voltage rating shall appear on the fuseholder body but the location of each is optional.

FIGURE 1. Type FHN28W and Type FHN28WB fuseholder. - Continued.

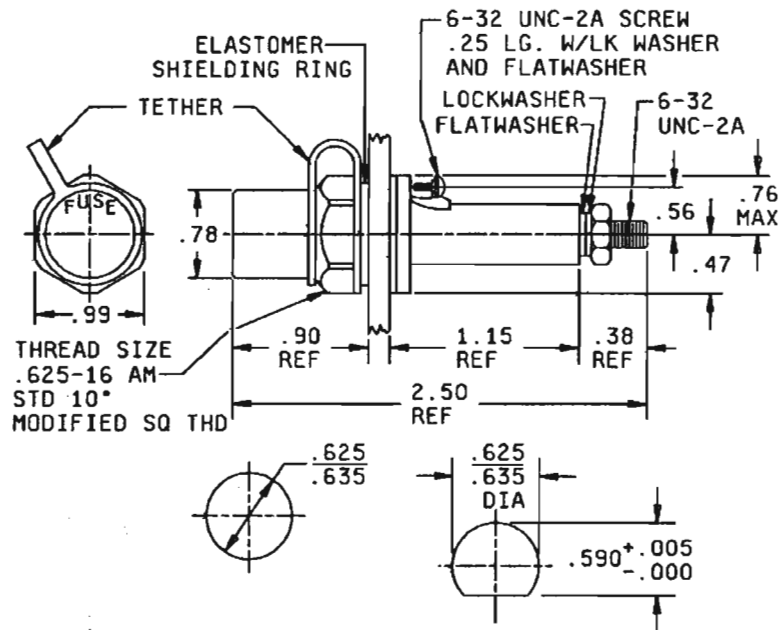

Inches	mm	Inches	mm	Inches	mm
.005	0.13	.56	14.22	.78	19.81
.190	4.83	.590	14.99	.90	22.86
.25	6.35	.625	15.88	.99	25.15
.38	9.65	.635	16.13	1.15	29.21
.47	11.94	.76	19.30	2.50	63.50

NOTES:

1. Dimensions are in inches.
2. Metric equivalents are given for general information only.
3. Unless otherwise specified, tolerances are ± 0.02 (0.51 mm) for two-place decimals and ± 0.005 (0.13 mm) for three-place decimals.
4. Cap thread shall be 3/8-32NEF2 and provide for cap interchangeability.

FIGURE 2. Type FHN28WS and Type FHN28WBS fuseholder.

5. Round hole mounting for replacement only. Use adapter washer for nonwatertight and non EMI/RFI applications only.
6. Marking: In addition to other required marking, the manufacturer's identification, the type designation, and the current and voltage rating shall appear on the fuseholder body but the location of each is optional.

FIGURE 2. Type FHN28WS and Type FHN28WBS fuseholder. - Continued.

REQUIREMENTS:

Interface and physical dimensions: See figure 1.

Cap and body molding material: Cap and body molding materials shall be selected to enable the fuseholder to meet the performance requirements of this specification. Additional information and guidance on body molding material are specified in the notes.

Fuse accommodation:

Ferrule type:

Size: 0.250 inch (6.35 mm) diameter, 1.250 inches (31.75 mm) length.

Style: MIL-PRF-15160, F02 and F03 and MIL-PRF-23419, FM09.

Poles: One.

Rating: 30 amperes, 250 volts maximum.

Panel thickness: 0.125 inch (3.18 mm) maximum.

Nonindicating:

Lamp series resistor: None.

Terminals: Threaded stud and screw type.

Enclosure: Watertight (FHN28W), watertight with EMI/RFI shielding (FHN28WS), watertight and body sealed (FHN28WB) or watertight and body sealed with EMI/RFI shielding (FHN28WBS).

Test fuses:

Temperature rise: F03A125V30A of MIL-PRF-15160/03.

Voltage drop: F03A125V30A of MIL-PRF-15160/03.

Short circuit: F03A250V15A of MIL-PRF-15160/03.

Mechanical shock: Method I of MIL-PRF-19207.

Terminal strength: 20 pounds.

Torque:

Threaded terminals: 12 inch-pounds.

Cap metal insert: 36 inch-pounds.

Mounting: 15 - 20 inch-pounds.

Salt spray (corrosion): Test condition B.

MIL-PRF-19207/17G

Dielectric:

Sea level: 1,500 volts.

Reduced pressure: 625 volts.

EMI/RFI shielding: Paragraph 3.5.18 of MIL-PRF-19207.

Type designation: Watertight (FHN28W), watertight with EMI/RFI shielding (FHN28WS), watertight and body sealed (FHN28WB) or watertight and body seal with EMI/RFI shielding (FHN28WBS).

TABLE I. Supersession information.

Superseding type designation number	Superseded MIL dash number
FHN28W	M19207/17-001
FHN28WS	N/A
FHN28WB	M19207/17-002
FHN28WBS	N/A

NOTES:

1. Body molding material: It is recommended that type MAI-60 or GDI-30F of American Society For Testing and Materials (ASTM) ASTM D5948 be considered for meeting the body molding material requirements of this specification.
2. EMI/RFI shielded type fuseholders are equivalent to the non-shielded type fuseholders with the addition of EMI/RFI shielding cap and mounting nut assembly.
3. To assure maximum shielding effectiveness mounting nut must be torqued to 15-20 inch-pounds over an electrically conductive panel surface, 1.01 inch minimum diameter.
4. For submarine applications, order type FHN28WB and FHN28WBS.

* Referenced documents. In addition to MIL-PRF-19207, this document references the following:

ASTM D5948

* The margins of this specification are marked with asterisks to indicate where changes from the previous issue were made. This was done as a convenience only and the Government assumes no liability whatsoever for any inaccuracies in these notations. Bidders and contractors are cautioned to evaluate the requirements of this document based on the entire content irrespective of the marginal notations and relationship to the last previous issue.