

INCH-POUND

  
MIL-PRF-19207/24K  
30 March 2001  

---

SUPERSEDING  
MIL-PRF-19207/24J  
22 June 1999

PERFORMANCE SPECIFICATION SHEET

FUSEHOLDERS, EXTRACTOR POST TYPE, BLOWN FUSE INDICATING,  
NON-EM/RFI SHIELDED AND EM/RFI SHIELDED,  
TYPE FHL35W AND TYPE FHL35WS

This specification is approved for use by all Departments  
and Agencies of the Department of Defense.

The requirements for acquiring the product described herein  
shall consist of this specification and MIL-PRF-19207.

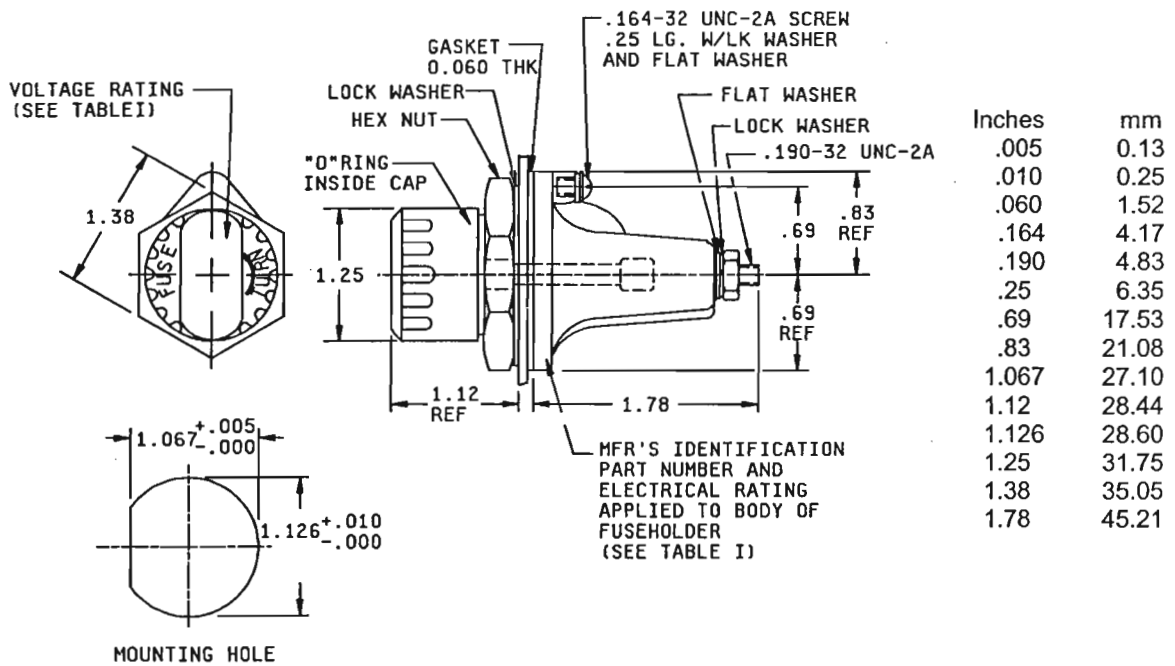

NOTES:

1. Dimensions are in inches.
2. Metric equivalents are given for general information only.
3. Unless otherwise specified, tolerances are ±0.02 (0.51 mm) for two-place decimals and ±0.005 (0.13 mm) for three-place decimals.
4. The location (on the fuseholder body) of the manufacturer's identification and electrical rating is optional.

FIGURE 1. Type FHL35W fuseholder.

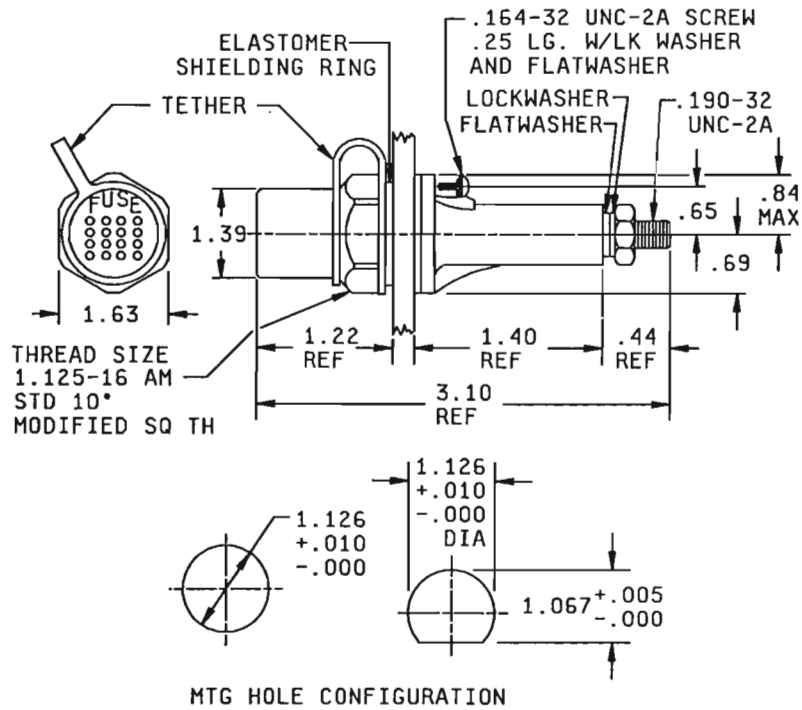

Inches	mm	Inches	mm
.010	0.25	1.067	27.10
.164	4.17	1.125	28.57
.190	4.83	1.126	28.60
.25	6.35	1.22	30.99
.44	11.18	1.39	35.30
.55	13.97	1.40	35.56
.65	16.51	1.63	41.40
.69	17.53	3.10	78.74
.84	21.33		

NOTES:

1. Dimensions are in inches.
2. Metric equivalents are given for general information only.
3. Unless otherwise specified, tolerances are  $\pm 0.02$  (0.51 mm) for two-place decimals and  $\pm 0.005$  (0.13 mm) for three-place decimals.
4. The location (on the fuseholder body) of the manufacturer's identification and electrical rating is optional.

FIGURE 2. Type FHL35WS fuseholder.

MIL-PRF-19207/24K

REQUIREMENTS:

Interface and physical dimensions: See figure 1 and 2.

Body molding material: Body molding materials shall be selected to enable the fuseholder to meet the performance requirements of this specification. Additional information and guidance on body molding material are specified in the notes.

Fuse accommodation:

Ferrule type:

Size: 0.406 inch (25.4 mm) diameter, 1.500 inches (38.10 mm) length.

Style: MIL-PRF-15160, F07, F09 and F60.

Poles: One.

Rating: 30 amperes, voltage see table I.

Panel thickness: 0.125 inch (3.18 mm) maximum.

Indicating: See table I.

Lamp series resistor: See table I

Terminals: Threaded stud and screw type.

Enclosure: Watertight (FHL35W), or watertight with EMI/RFI shielding (FHL35WS).

Test fuses:

Temperature rise: F60C500V30A of MIL-PRF-15160/60.

Short circuit: F60C500V30A of MIL-PRF-15160/60.

Mechanical shock: Method I of MIL-PRF-19207.

Terminal strength: 20 pounds.

Torque:

Threaded terminals: 25 inch-pounds.

Mounting: 15-20 inch-pounds.

Cap insert: 15 inch-pounds.

Salt spray (corrosion): Test condition B.

EMI/RFI shielding: Paragraph 3.5.18 of MIL-PRF-19207.

Type designation: Watertight FHL35W- (dash number from table I). Watertight with EMI/RFI shielding FHL35WS- (dash number from table I).

MIL-PRF-19207/24K

TABLE I. Voltage and resistance.

Type Designation dash no.	Voltage	Lamp indicator number 1/	Resistance	Resistor type	Resistor specification	Cap color
-01 2/	12-22	1764	Shorting wire	N/A	N/A	Amber
-02 2/	23-33	1764	330	RLR07C 1/4 watt	MIL-R-39017/1	Amber
-03 2/	34-45	1764	680	RLR07C 1/4 watt	MIL-R-39017/1	Amber
-04 2/	46-60	1764	1,200	RLR07C 1/4 watt	MIL-R-39017/1	Amber
-05 2/	61-80	1764	1,800	RLR07C 1/4 watt	MIL-R-39017/1	Amber
-06 2/	81-90	1764	2,000	RLR07C 1/4 watt	MIL-R-39017/1	Amber
-07 2/	2.5-4	1784	Shorting wire	N/A	N/A	Amber
-08 2/	5-7	1705	Shorting wire	N/A	N/A	Amber
-09 2/	8-11	1705	Shorting wire	N/A	N/A	Amber
-10 2/	1-2.4	2169	Shorting wire	N/A	N/A	Amber
-11 3/	90-250	Neon	330,000	RLR07C 1/2 watt	MIL-R-39017/2	Clear
-12 3/	90-500	Neon	330,000	RLR07C 1/2 watt	MIL-R-39017/2	Clear

1/ Industry number.

2/ For a clear cap color, the designator "C" is added after the dash number.

3/ This fuseholder is only available with a clear cap color.

*RLR20C 1/2 watt*

*SEE AMENDMENT*

TABLE II. Supersession information.

Superseding type designation dash number	Superseded DESC Drawing	Superseded MIL dash number	Superseding type Designation dash number	Superseded DESC Drawing	Superseded MIL Dash number
FHL35W-01 1/	N/A	M19207/24-01	FHL35WS-09	86004-09	N/A
FHL35WS-01	86004-01	N/A	FHL35W-10 1/	N/A	M19207/24-10
FHL35W-02 1/	N/A	M19207/24-02	FHL35WS-10	86004-10	N/A
FHL35WS-02	86004-02	N/A	FHL35W-11 1/	N/A	M19207/24-11
FHL35W-03 1/	N/A	M19207/24-03	FHL35WS-11	86004-11	N/A
FHL35WS-03	86004-03	N/A	FHL35W-12 1/	N/A	M19207/24-12
FHL35W-04 1/	N/A	M19207/24-04	FHL35WS-12	86004-12	N/A
FHL35WS-04	86004-04	N/A	FHL35W-01C	N/A	FHL35W-13
FHL35W-05 1/	N/A	M19207/24-05	FHL35W-02C	N/A	FHL35W-14
FHL35WS-05	86004-05	N/A	FHL35W-03C	N/A	FHL35W-15
FHL35W-06 1/	N/A	M19207/24-06	FHL35W-04C	N/A	FHL35W-16
FHL35WS-06	86004-06	N/A	FHL35W-05C	N/A	FHL35W-17
FHL35W-07 1/	N/A	M19207/24-07	FHL35W-06C	N/A	FHL35W-18
FHL35WS-07	86004-07	M19207/24-08	FHL35W-07C	N/A	FHL35W-19
FHL35W-08 1/	N/A	N/A	FHL35W-08C	N/A	FHL35W-20
FHL35WS-08	86004-08	N/A	FHL35W-09C	N/A	FHL35W-21
FHL35W-09 1/	N/A	M19207/24-09	FHL35W-10C	N/A	FHL35W-22

1/ FHL35W-XX has been re-established to the type designation used prior to revision H."

MIL-PRF-19207/24K

NOTES:

1. Body molding material: It is recommended that type MAI-60 or GDI-30F of American Society For Testing and Materials (ASTM) ASTM D5948 be considered for meeting the body molding material requirements of this specification.
2. EMI/RFI shielded type fuseholders are equivalent to the non-shielded type fuseholders with the addition of EMI/RFI shielding cap and mounting nut assembly.
3. To assure maximum shielding effectiveness mounting nut must be torqued to 15-20 inch-pounds over an electrically conductive panel surface, 1.63 inch minimum diameter.

Marginal notations are not used in this revision to identify changes with respect to the previous issue due to the extent of the changes.

Custodians:

Army - CR  
Navy - SH  
Air Force - 11  
DLA - CC

Preparing activity:

DLA - CC

(Project 5920-0728-04)

Review activities:

Army - AR, AT, CR4, MI  
Navy - AS, EC, MC, OS  
Air Force - 70, 71, 80

INCH-POUND

MIL-PRF-19207/24K  
AMENDMENT 1  
25 October 2001

PERFORMANCE SPECIFICATION SHEET

FUSEHOLDERS, EXTRACTOR POST TYPE, BLOWN FUSE INDICATING,  
NON-EMI/RFI SHIELDED AND EMI/RFI SHIELDED,  
TYPE FHL35W AND TYPE FHL35WS

This amendment forms a part of MIL-PRF-19207/24K, dated 30 March 2001, and is approved for use by all Departments and Agencies of the Department of Defense.

PAGE 4

TABLE I, Resistor type column, delete "RLR07C ½ watt" and substitute "RLR20C ½ watt".

Custodians:

Army - CR  
Navy - SH  
Air Force - 11  
DLA - CC

Preparing activity:  
DLA - CC

(Project 5920-0756)

Review activities:

Army - AR, AT, CR4, MI  
Navy - AS, EC, MC, OS  
Air Force - 70, 71, 80