

INCH-POUND

MIL-PRF-19207/19L

22 September 2004

SUPERSEDING

MIL-PRF-19207/19K

26 April 1999

PERFORMANCE SPECIFICATION SHEET

FUSEHOLDERS, EXTRACTOR POST TYPE,
BLOWN FUSE INDICATING, TYPE FHL30G

This specification is approved for use by all Departments and Agencies of the Department of Defense.

The requirements for acquiring the product described herein shall consist of this specification sheet and MIL-PRF-19207.

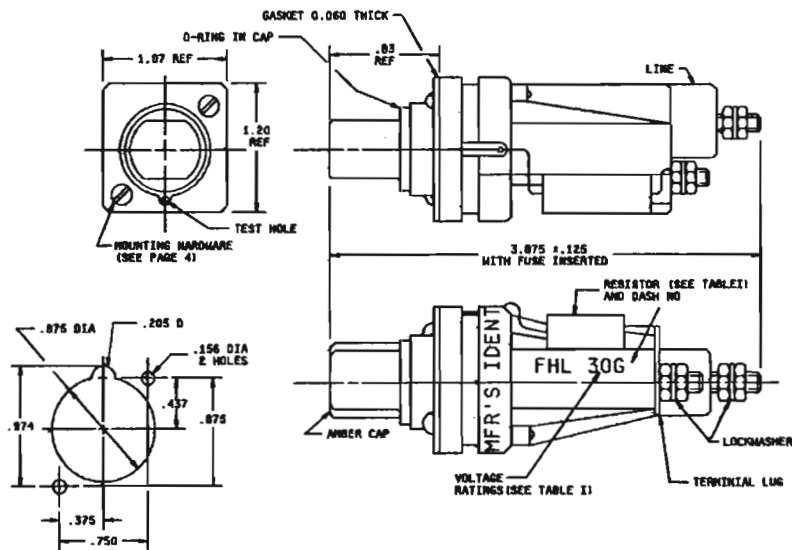

Inches	mm	Inches	mm
0.005	0.13	.750	19.05
0.060	1.52	.83	21.08
.125	3.18	.875	22.23
.156	3.96	.974	24.74
.205	5.21	1.070	27.18
.375	9.53	1.200	30.48
.437	11.10	3.875	98.43

FIGURE 1. Type FHL30G fuseholder

NOTES:

1. Dimensions are in inches. Metric equivalents are given for general information only.
2. Unless otherwise specified, tolerances are .XX ± 0.02 and .XXX ± 0.005.
3. All of the type FHL30G fuseholders submitted for delivery shall have been subjected to the drip-proof test in accordance with MIL-PRF-19207, 4.6.16.2.
4. Mounting hardware: Screws, sealing, panhead, slotted, stainless steel or zinc plated steel, 6-32UNC-2A x 1.125 inches (28.58 mm) long (min) or 6-32UNC-2A x 1.125 inches (28.58 mm) long (min) with sealing washer, 2 each. Mounting hardware and gasket may be provided loose in a plastic bag or installed on the fuseholder
5. Body material: It is recommended that type MAI-60 or GDI-30F of American Society For Testing and Materials (ASTM) ASTM D5948 be considered for meeting the body molding material requirements of this specification.
6. Marking: In addition to other required marking, the manufacturer's identification, the type designation with an appropriate dash number, and the voltage rating from table I shall appear on the fuseholder body but the location of each is optional.

FIGURE 1. Type FHL30G fuseholder - Continued.

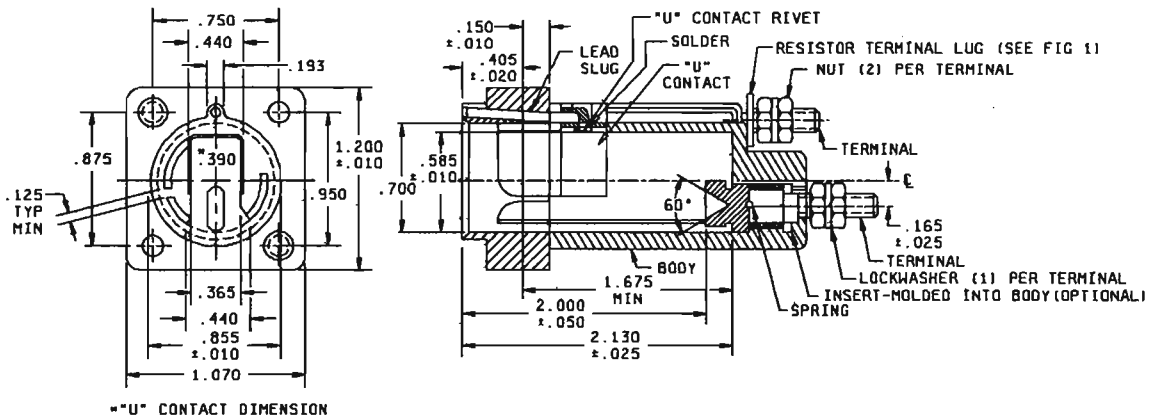

Inches	mm	Inches	mm	Inches	mm	Inches	mm	Inches	mm
.010	0.25	.150	3.81	.440	11.18	.875	22.23	2.000	50.80
.020	0.51	.165	4.19	.585	14.86	.950	24.13	2.130	54.10
.025	.064	.193	4.90	.700	17.78	1.070	27.18		
.050	1.27	.365	9.27	.750	19.05	1.200	30.48		
.125	3.18	.405	10.29	.855	21.72	1.675	42.55		

FIGURE 2. Body for FHL30G fuseholder.

NOTES:

1. Dimensions are in inches. Metric equivalents are given for general information only.
2. Unless otherwise specified, tolerances are $.XX \pm 0.02$ and $.XXX \pm 0.005$.
3. All of the type FHL30G fuseholders submitted for delivery shall have been subjected to the drip-proof test in accordance with MIL-PRF-19207, 4.6.16.2.
4. Mounting hardware: Screws, sealing, panhead, slotted, stainless steel or zinc plated steel, 6-32UNC-2A x 1.125 inches (28.58 mm) long (min) or 6-32UNC-2A x 1.125 inches (28.58 mm) long (min) with sealing washer, 2 each. Mounting hardware and gasket may be provided loose in a plastic bag or installed on the fuseholder
5. Body material: It is recommended that type MAI-60 or GDI-30F of American Society For Testing and Materials (ASTM) ASTM D5948 be considered for meeting the body molding material requirements of this specification.
6. Marking: In addition to other required marking, the manufacturer's identification, the type designation with an appropriate dash number, and the voltage rating from table I shall appear on the fuseholder body but the location of each is optional.

FIGURE 2. Body for FHL30G fuseholder - Continued.

REQUIREMENTS:

Dimensions and configuration: See figures 1 and figure 2.

Body material: Body material shall be selected to enable the fuseholder to meet the performance requirements of this specification. Additional information and guidance on body material is specified in the notes of figures 1 and 2.

Fuse accommodation, Ferrule type:

Size: 0.250 inch (6.35 mm) diameter, 1.250 (31.75 mm) inches in length.

Styles: F02 and F03 in accordance with MIL-PRF-15160, and FM09 in accordance with MIL-PRF-23419.

Poles: One.

Rating: 30 amperes (see table I for voltage ratings).

Panel thickness: 0.125 inch (3.18 mm) maximum.

Indicating: Incandescent lamp, industry No. 1764, with Amber color cap.

Terminals: Threaded stud type, No. 8-32UNC-2A thread. Brass, silver, or tin plate.

Enclosure: Drip-proof (see note 4).

Test fuses:

Temperature rise: F03A125V30A in accordance with MIL-PRF-15160/3.

Short circuit: F03A125V30A in accordance with MIL-PRF-15160/3.

Mechanical shock: Method I in accordance with MIL-PRF-19207.

Terminal strength: 20 pounds.

Torque: Terminals - 15 inch-pounds.

Salt spray (corrosion): Test condition B.

Mounting hardware:

Mounting plate: A threaded metal insert may be used in lieu of mounting plate.

Type designation: FHL30G (dash number from table I).

Patent notice: The US Government has royalty-free license only under claims 3 through 6, 11, and 12 of US Patent 2,854,549 owned by McGraw Electric Company for the benefit of manufacturers of the items called for in this specification sheet either for the Government or for use in equipment to be delivered to the Government.

TABLE I. Fuseholder marking.

Fuseholder marking		Resistance (ohms)	Resistance specification	Style
Type designation dash number	Voltage (volts)			
-001	12-22	Shorting wire in place of resistor		
-002	23-33	330	MIL-PRF-39017/2	-RLR20
-003	34-45	681	MIL-PRF-39007/8	-RWR80
-004	46-60	1,210	MIL-PRF-39007/8	-RWR80
-005	61-80	1,870	MIL-PRF-39007/11	-RWR89
-006	81-90	2,050	MIL-PRF-39007/11	-RWR89

Referenced documents. In addition to MIL-PRF-19207, this document references the following:

MIL-PRF-15160, MIL-PRF-15160/3 MIL-PRF-23419

ASTM D5948

The margins of this specification are marked with asterisks to indicate where changes from the previous issue were made. This was done as a convenience only and the Government assumes no liability whatsoever for any inaccuracies in these notations. Bidders and contractors are cautioned to evaluate the requirements of this document based on the entire content irrespective of the marginal notations and relationship to the last previous issue.

Custodians:

Army - CR
Navy - SH
Air Force - 11
DLA - CC

Preparing activity:
DLA - CC

(Project 5920-0846)

Review activities:

Army - AR, AT, CR4, MI
Navy - AS, EC, MC, OS
Air Force - 19, 70, 71, 99

NOTE: The activities listed above were interested in this document as of the date of this document. Since organizations and responsibilities can change, you should verify the currency of the information above using the ASSIST Online database at <http://www.dodssp.daps.mil>.