

PERFORMANCE SPECIFICATION SHEET

FUSEHOLDERS, EXTRACTOR POST TYPE,
BLOWN FUSE INDICATING, TYPE FHL29G

This specification is approved for use by all Departments and agencies of the Department of Defense.

The requirement for acquiring the product described herein shall consist of this specification and MIL-PRF-19207.

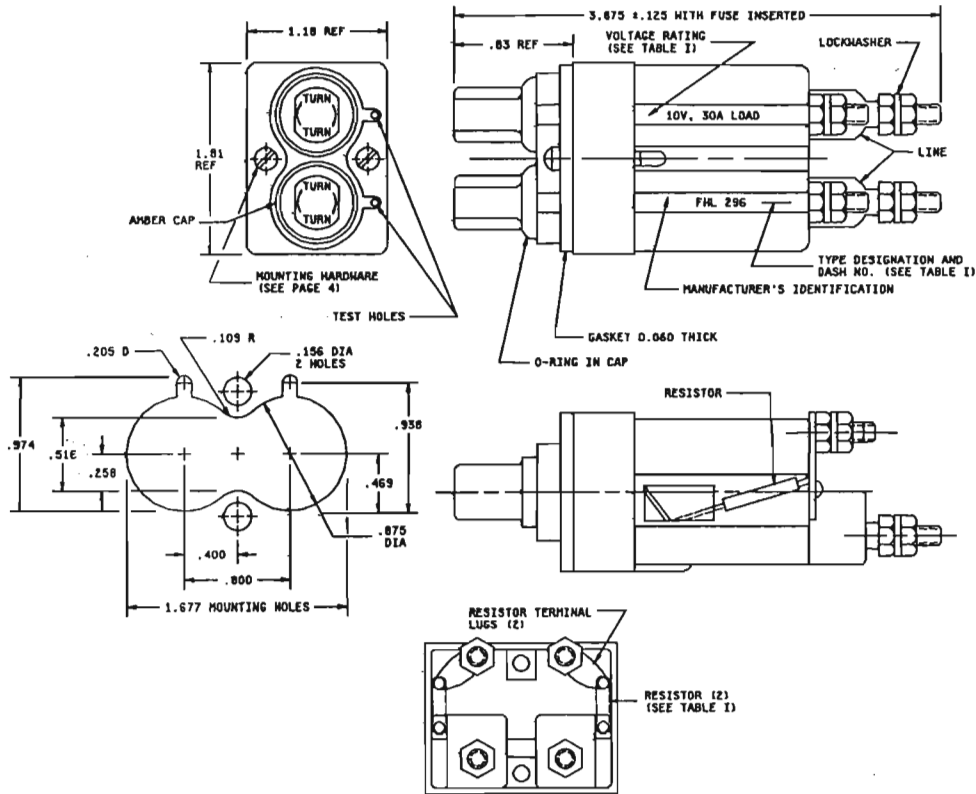

Inches	mm	Inches	mm	Inches	mm
.060	1.52	.400	10.16	.974	24.74
.109	2.77	.469	11.91	1.180	29.97
.125	3.18	.516	13.11	1.677	42.60
.156	3.96	.800	20.32	1.810	45.97
.205	5.21	.875	22.23	3.875	98.43
.258	6.55	.938	23.83		

See notes at end of figures.

FIGURE 1. Type FHL29G fuseholder.

MIL-PRF-19207/18H

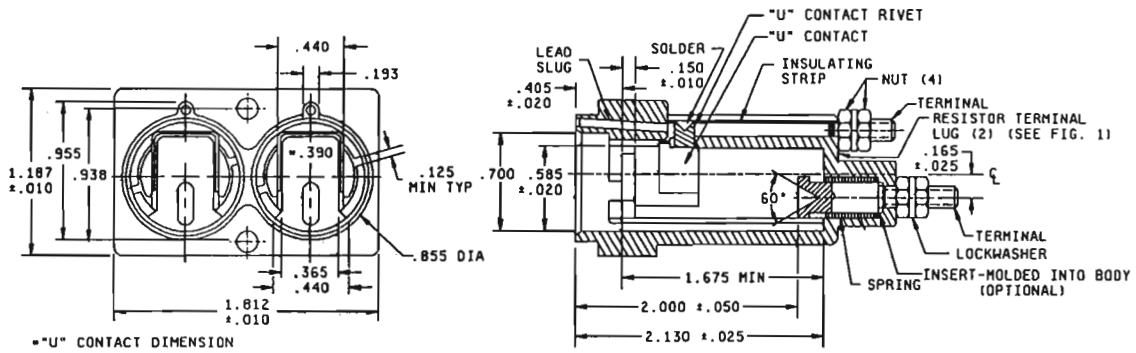

<u>Inches</u>	<u>mm</u>	<u>Inches</u>	<u>mm</u>	<u>Inches</u>	<u>mm</u>
.010	0.25	.365	9.27	.938	23.83
.020	0.51	.390	9.91	.950	24.13
.025	0.64	.405	10.29	1.180	29.97
.050	1.27	.440	11.18	1.675	42.55
.125	3.18	.585	14.86	1.812	46.02
.150	3.81	.700	17.78	2.000	50.80
.165	4.19	.855	21.72	2.130	54.10
.193	4.90				

See notes at end of figures.

FIGURE 2. Body for FHL29G fuseholder.

MIL-PRF-19207/18H

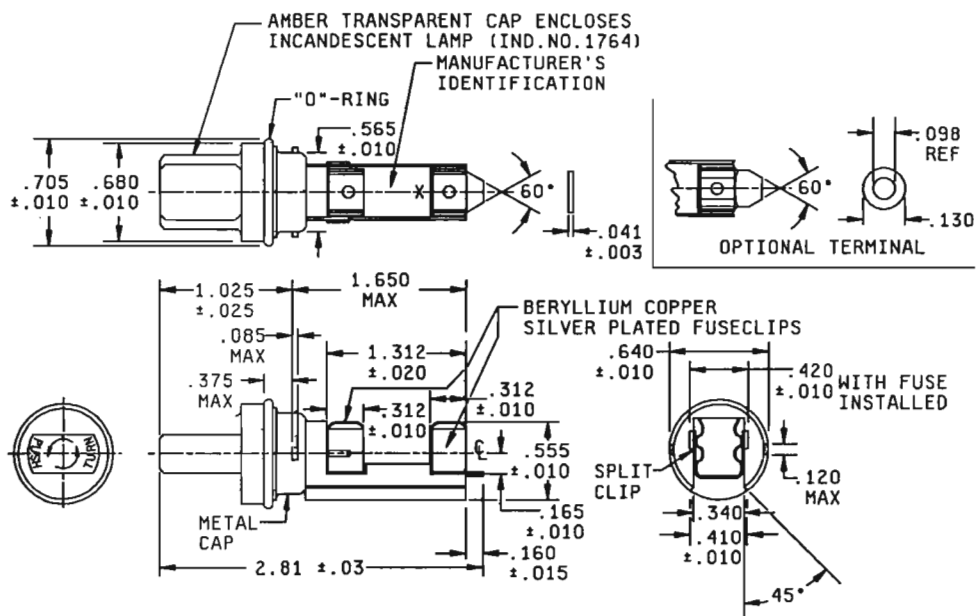

Inches	mm	Inches	mm	Inches	mm
.003	0.08	.120	3.05	.555	14.10
.010	0.25	.130	3.30	.565	14.35
.015	0.38	.160	4.06	.640	16.26
.020	0.51	.165	4.19	.680	17.27
.025	0.64	.312	7.92	.705	17.91
.031	0.79	.340	8.64	1.025	26.04
.041	1.04	.375	9.53	1.312	33.32
.085	2.16	.410	10.41	1.650	41.91
.098	2.49	.420	10.67	2.813	71.45

NOTES:

- Dimensions are in inches. Metric equivalents are for general information only, based upon 1 inch = 25.4 mm.
- Unless otherwise specified, tolerances are ±.02 (0.51 mm) for two place decimals and ±.005 (0.31 mm) for three place decimals.
- Cap and body molding material: It is suggested that type MAI-60, GDI-30F or SDG-F of American Society for Testing and Materials ASTM-D5948 be considered for meeting the cap and body molding material requirements of this specification. ASTM-D3935 is also suggested as guidance for cap material.
- All of the type FHL29G fuseholders submitted for delivery shall have been subjected to the dripproof test in accordance with 4.6.16.2 of MIL-PRF-19207.
- Mounting hardware:
 - Screw: 6-32UNC-2A, .875 inch (21.46 mm) long (minimum).
Pan/round head with sealing washer or pan self sealing.
 - Nut: 6-32 UNC-2B square. A threaded metal insert may be used in lieu of nut.

FIGURE 3. Fuse carrier for FHL29G and FHL30G fuseholders.

MIL-PRF-19207/18H

REQUIREMENTS:

Interface and physical dimensions: See figures 1, 2, and 3.

Cap and body molding material: Cap and body molding materials shall be selected to enable the fuseholder to meet the performance requirements of this specification. Additional information and guidance on body molding material are specified in the notes.

Fuse accommodation, ferrule type:

Size: .250 inch (6.35 mm) diameter, 1.250 inches (31.75 mm) length.

Styles: F02 and F03 in accordance with MIL-PRF-15160, and FM09 in accordance with MIL-PRF-23419. (or equivalent size and styles)

Poles: Two.

Rating: 30 amperes (see table I for voltage ratings).

Part or Identifying Number (PIN): FHL29G (dash number from table I).

TABLE I. Fuseholder marking.

Fuseholder marking		Resistance (ohms)	Resistance specification	Style
PIN dash number	Voltage			
-001	12-22	Shorting wire in place of resistor		
-002	23-33	330	MIL-PRF-39017/2	RLR20
-003	34-45	681	MIL-PRF-39007/8	RWR80
-004	46-60	1,210	MIL-PRF-39007/8	RWR80
-005	61-80	1,870	MIL-PRF-39007/11	RWR89
-006	81-90	2,050	MIL-PRF-39007/11	RWR89

Panel thickness: .125 inch (3.18 mm) maximum.

Indicating: Incandescent lamp, No. 1764, with amber clear cap.

Lamp series resistor: See table I.

Terminals: Threaded stud type, No. 8-32UNC-2A, brass, silver, or tin plate.

Enclosure: Dripproof. See note 5.

Test fuses:

Temperature rise: F03A125V30A in accordance with MIL-PRF-15160/3.

Short circuit: F03A125V30A in accordance with MIL-PRF-15160/3.

Mechanical shock: Method I in accordance with MIL-PRF-19207.

Terminal strength: 20 pounds.

Torque: Terminals - 15 inch-pounds.

Salt spray (corrosion): Test condition B.

MIL-PRF-19207/18H

Patent notice: The US Government has royalty-free license only under claims 3 through 6, 11, and 12 of US Patent 2,854,549 owned by McGraw Electric Company for the benefit of manufacturers of the items called for in this specification sheet either for the Government or for use in equipment to be delivered to the Government.

Marginal notations are not used in this version to identify changes with respect to the previous issue due to the extent of the changes

Custodians:

Army - CR
Navy - SH
Air Force - 11
DLA - CC

Preparing activity:

DLA - CC
(Project 5920-0667)

Review activities:

Army - AR, AT, CR4, MI
Navy - AS, EC, MC, OS
Air Force - 70, 71, 99