

PERFORMANCE SPECIFICATION SHEET  
 FUSEHOLDERS, EXTRACTOR POST TYPE,  
 BLOWN FUSE INDICATING, TYPES FHL10U AND FHL10G

This specification is approved for use by all Departments and Agencies of the Department of Defense

The requirements for acquiring the product described herein shall consist of this specification and MIL-PRF-19207.

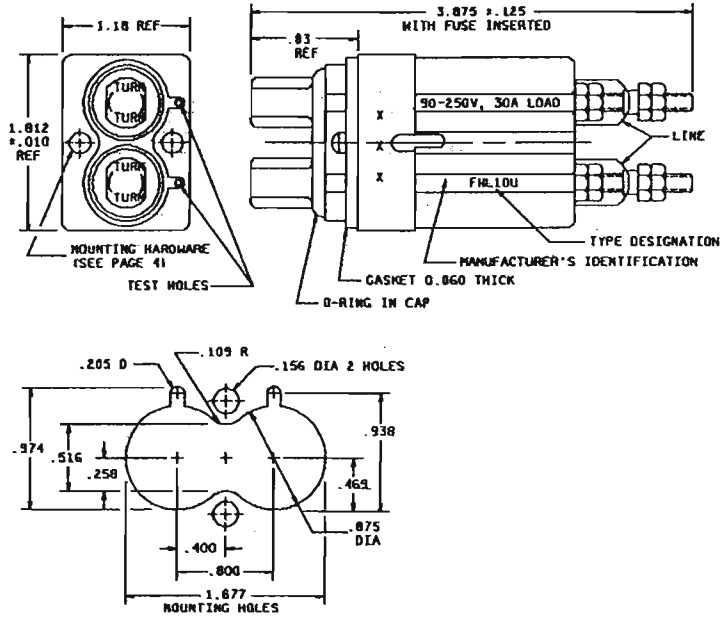

Inches	mm	Inches	mm	Inches	mm	Inches	mm	Inches	mm
.060	1.52	.205	5.21	.516	13.11	.938	23.83	1.810	45.97
.109	2.77	.258	6.55	.800	20.32	.974	24.74	3.875	98.43
.125	3.18	.400	10.16	.830	21.08	1.180	29.97		
.156	3.96	.469	11.91	.875	22.23	1.677	42.60		

- NOTES:
1. Dimensions are in inches.
  2. Metric equivalents are given for general information only.
  3. Unless otherwise specified, tolerances are  $\pm 0.02$  (0.51 mm) for two place decimals and  $\pm 0.005$  (0.13mm) for three-place decimals.

FIGURE 1. Type FHL10U and type FHL10G fuseholders.

Part or Identifying Number (PIN): FHL10U-001 - Body for FHL10U  
 FHL10G-002 - Body for FHL10G

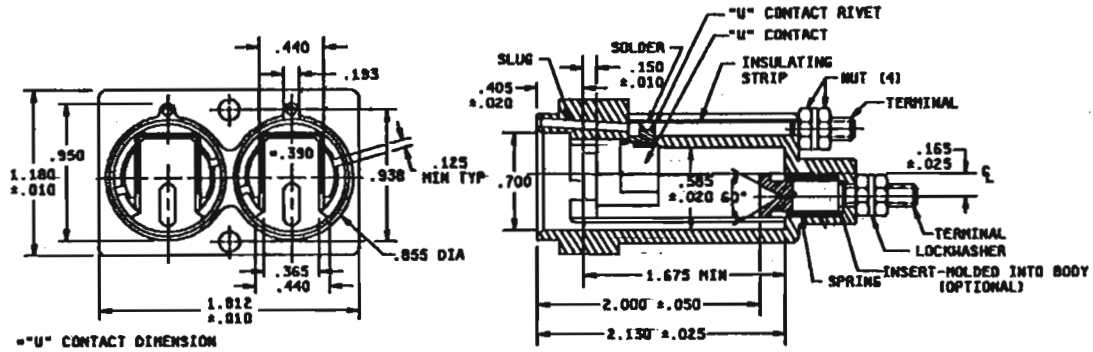

Inches	mm	Inches	mm	Inches	mm	Inches	mm	Inches	mm
.010	0.25	.150	3.81	.405	10.29	.938	23.83	2.000	50.80
.020	0.51	.165	4.19	.440	11.18	.950	24.13	2.130	54.10
.025	0.64	.193	4.90	.585	14.86	1.180	29.97		
.050	1.27	.365	9.27	.700	17.78	1.675	42.55		
.125	3.18	.390	9.91	.855	21.72	1.812	46.02		

FIGURE 2. Body for FHL10U and FHL10G fuseholders.

Part or Identifying Number (PIN): FHL10U-003 - Fuse carrier for FHL10U  
 FHL10G-004 - Fuse carrier for FHL10G

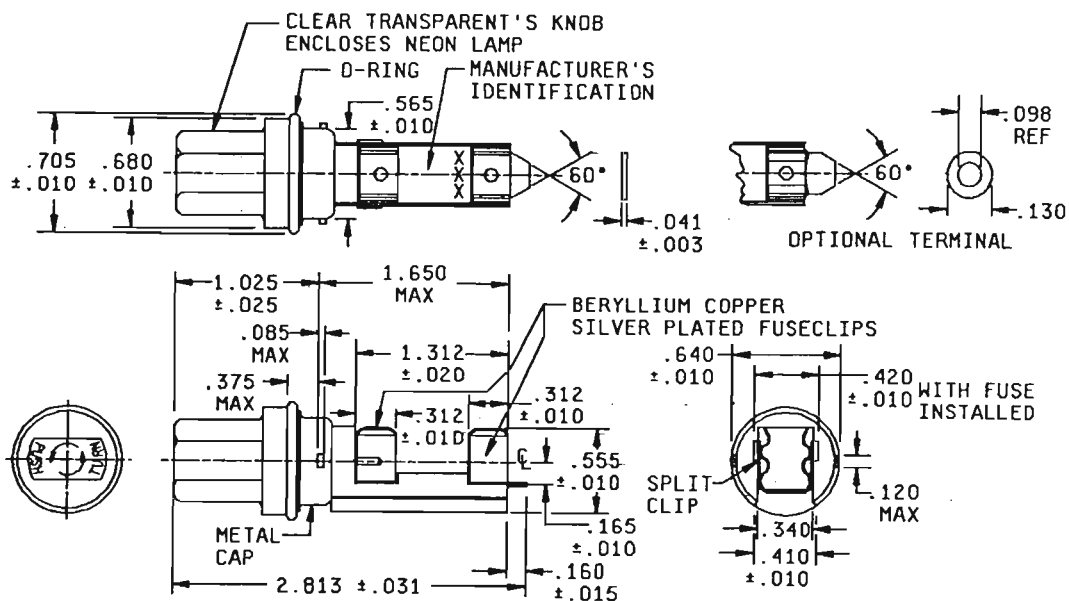

Inches	mm	Inches	mm	Inches	mm	Inches	mm	Inches	mm
.003	0.08	.041	1.04	.165	4.19	.555	14.10	1.312	33.32
.010	0.25	.085	2.16	.312	7.92	.565	14.35	1.650	41.91
.015	0.38	.098	2.49	.340	8.64	.640	16.26	2.813	71.45
.020	0.51	.120	3.05	.375	9.53	.680	17.27		
.025	0.64	.130	3.30	.410	10.41	.705	17.91		
.031	0.79	.160	4.06	.420	10.67	1.025	26.04		

FIGURE 3. Fuse carrier for FHL10U and FHL10G fuseholders.

REQUIREMENTS:

Interface and physical dimensions: See figures 1, 2, and 3.

Cap and body molding material: Cap and body molding materials shall be selected to enable the fuseholder to meet the performance requirements of this specification. Additional information and guidance on body molding material are specified in the notes.

Fuse accommodation.

Ferrule type:

Size: 0.250 inch (0.64 mm) diameter, 1.250 inches (31.75 mm) length.

Styles: MIL-PRF-15160, F02 and F03 and MIL-PRF-23419, FM09.

(or equivalent size and style)

Poles: Two.

Rating: 30 amperes, 90-250 volts.

Panel thickness: 0.125 inch (3.18 mm) maximum.

Indicating: Neon lamp with clear cap.

Lamp series resistor: MIL-PRF-39017/1, 120,000 ohms, 0.25 watt.

Terminals: Stud type, No. 8-32 UNC-2A thread.

Enclosure: Unsealed: FHL10U.  
Drip-proof: FHL10G (see note 1)

Test fuses:

Temperature rise: F03A125V30A of MIL-PRF-15160/3.

Short circuit: F03A250V15A of MIL-PRF-15160/3.

Mechanical shock: Method I of MIL-PRF-19207.

Terminal strength: 20 pounds.

Torque: Terminals - 15 pounds-inch.

Salt atmosphere (corrosion): Test condition B.

Mounting hardware:

Screw: 6-32UNC-2A, 7/8-inch long (min).

Pan/round head with sealing washer or pan self-sealing.

Nut: 6-32UNC-2B square. A threaded metal insert may be used in lieu of nut.

NOTES:

1. All of the type FHL10G fuseholders submitted for delivery shall have been subjected to the drip-proof test as specified in 4.6.16.2 of MIL-PRF-19207.
2. Cap and body molding material: It is suggested that type MAI-60, GDI-30F or SDG-F of American Society for Testing and Materials ASTM-D5948 be considered for meeting the cap and body molding material requirements of this specification. ASTM-D3935 is also suggested as guidance for cap material.

Referenced documents. In addition to MIL-PRF-19207, this document references the following:

MIL-PRF-15160 MIL-PRF-15160/3 MIL-PRF-23419 MIL-PRF-39017/1

ASTM-D3935 ASTM-D5948

The margins of this specification are marked with vertical lines to indicate where changes from the previous issue were made. This was done as a convenience only and the Government assumes no liability whatsoever for any inaccuracies in these notations. Bidders and contractors are cautioned to evaluate the requirements of this document based on the entire content irrespective of the marginal notations and relationship to the last previous issue.

Custodians:

Army - CR  
Navy - SH  
Air force - 11  
DLA - CC

Preparing Activity:

DLA - CC

(Project 5920-2006-027)

Review Activities:

Army - AR, AT, CR4, MI  
Navy - AS, EC, MC, OS  
Air Force - 19, 70, 71, 84, 99

NOTE: the activities listed above were interested in this document as of the date of this document. Since organizations and responsibilities can change, you should verify the currency of the information above using the ASSIST Online database at <http://assist.daps.dla.mil>.